

# OMNI-X

2751 West Mansfield Ave., Englewood, CO 80110

1-800-275-6664

FAX: 303-789-4755

## BEND DIE ORDER FORM

Company Name \_\_\_\_\_  
 Purchase Order# \_\_\_\_\_  
 Job# \_\_\_\_\_

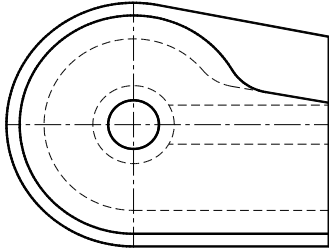

FULL PLATFORM

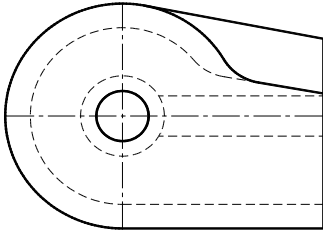

PARTIAL PLATFORM

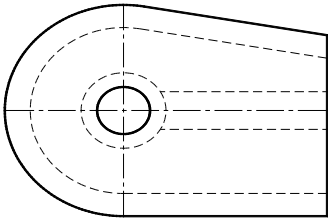

1 PC. 120

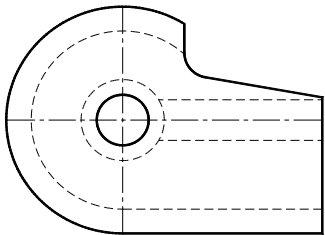

1 PC. 180

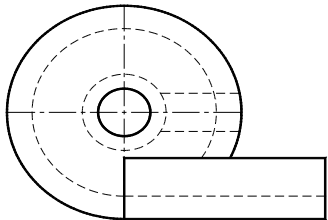

SPOOL (INSERTED GRIP)

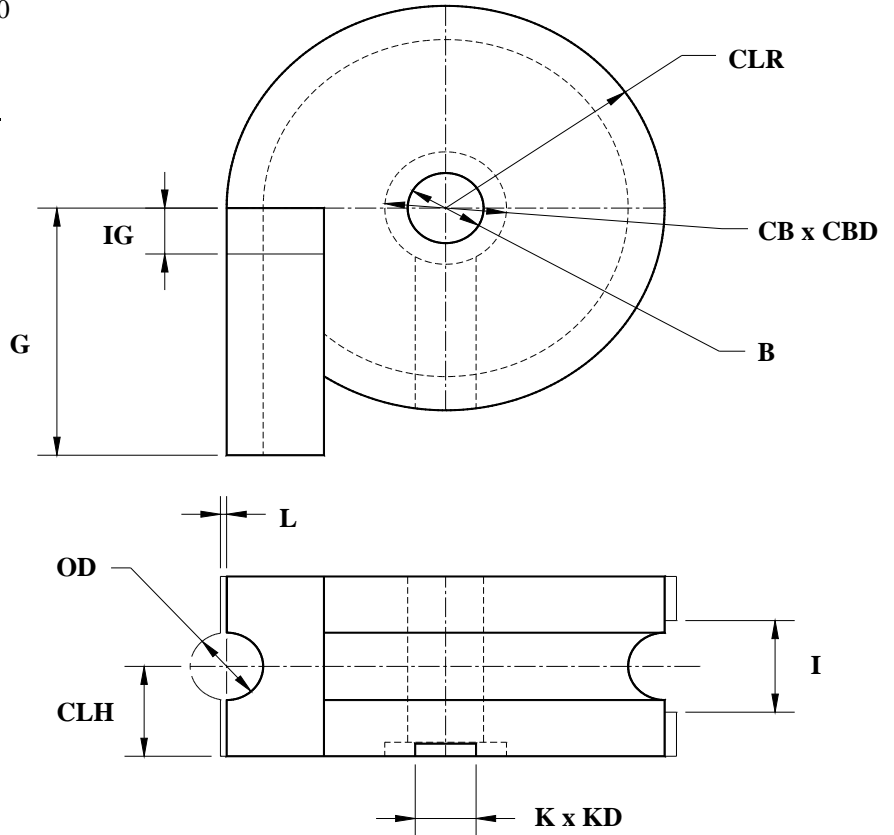

**WHEN ORDERING, PLEASE SPECIFY:**

Make and Model of Bending Machine \_\_\_\_\_  
 Serial # of Bending Machine \_\_\_\_\_  
 Rotation of Arm (Clockwise or Counter Clockwise) \_\_\_\_\_  
 Counter Bore: Diameter (CB) \_\_\_\_\_ x Depth (CBD) \_\_\_\_\_  
 Keyway: Width (K) \_\_\_\_\_ x Depth (KD) \_\_\_\_\_  
 Center Line Height of Tube Groove (CLH) \_\_\_\_\_  
 Interlock Yes  No       6% Lip (L) Yes  No

**TUBE INFORMATION:**

Outside Diameter (OD) \_\_\_\_\_  
 Center Line Radius (CLR) \_\_\_\_\_  
 Maximum Degree of Bend \_\_\_\_\_  
 Grip Length - Min. between Bends (G) \_\_\_\_\_

**OPTIONAL INFORMATIONS:**

Style of Bend Die Desired \_\_\_\_\_  
 Integral Grip Length (IG) \_\_\_\_\_  
 Interlock Dimension (I) \_\_\_\_\_  
 Mounting Bore Diameter (B) \_\_\_\_\_

Special Instructions: